



**INSTITUTO DE CIENCIAS  
DE LA CONSTRUCCIÓN  
EDUARDO TORROJA**

C/ Serrano Galvache n. 4 28033 Madrid (Spain)  
Tel.: (34) 91 302 04 40  
[direccion.ietcc@csic.es](mailto:direccion.ietcc@csic.es) <https://dit.ietcc.csic.es>

**European Technical  
Assessment**

**ETA 12/0397  
26/06/2024**

English translation prepared by IETcc. Original version in Spanish language

**General Part**

**Technical Assessment Body issuing the ETA designated according to Art. 29 of Regulation (EU) 305/2011:**

Instituto de Ciencias de la Construcción Eduardo Torroja (IETcc)

**Trade name of the construction product:  
Product family to which the construction product belongs:**

**Anchor MTP**

Torque controlled expansion anchor made of galvanized steel, sherardized steel or stainless steel of sizes M8, M10, M12, M16, M20 and M24 for use in cracked or uncracked concrete.

**Manufacturer:**

**Index - Técnicas Expansivas S.L.**  
Segador 13  
26006 Logroño (La Rioja) Spain.  
website: [www.indexfix.com](http://www.indexfix.com)

**Manufacturing plants:**

Index plant 2

**This European Technical Assessment contains:**

21 pages including 3 annexes which form an integral part of this assessment.

**This European Technical Assessment is issued in accordance with regulation (EU) No 305/2011, on the basis of:**

European Assessment Document EAD 330232-01-0601 "Mechanical fasteners for use in concrete", ed. December 2019

**This version replaces**

ETA 12/0397 version 6 issued on 24/10/2023

Código seguro de Verificación : GEN-54a0-5a64-7947-f2e5-0b5e-08a7-216e-eeef | Puede verificar la integridad de este documento en la siguiente dirección : <https://sede.administracion.gob.es/pagSedeFront/servicios/consultaCSV.htm>

CSV : GEN-54a0-5a64-7947-f2e5-0b5e-08a7-216e-eeef

DIRECCIÓN DE VALIDACIÓN : <https://sede.administracion.gob.es/pagSedeFront/servicios/consultaCSV.htm>

FIRMANTE(1) : ANGEL CASTILLO TALAVERA | FECHA : 22/08/2024 09:01 | Sin acción específica



English translation prepared by IETcc

This European Technical Assessment is issued by the Technical Assessment Body in its official language. Translations of this European Technical Assessment in other languages shall fully correspond to the original issued document and should be identified as such.

This European Technical Assessment may be withdrawn by the issuing Technical Assessment Body, in particular pursuant to information by the Commission according to article 25 (3) of Regulation (EU) No 305/2011.

Código seguro de Verificación : GEN-54a0-5a64-7947-f2e5-0b5e-08a7-216e-eeef | Puede verificar la integridad de este documento en la siguiente dirección :  
<https://sede.administracion.gob.es/pagSedeFront/servicios/consultaCSV.htm>

---

CSV : GEN-54a0-5a64-7947-f2e5-0b5e-08a7-216e-eeef

DIRECCIÓN DE VALIDACIÓN : <https://sede.administracion.gob.es/pagSedeFront/servicios/consultaCSV.htm>

FIRMANTE(1) : ANGEL CASTILLO TALAVERA | FECHA : 22/08/2024 09:01 | Sin acción específica



## SPECIFIC PART

### 1. Technical description of the product

The Index MTP wedge anchor in the range of M8, M10, M12, M16, M20 and M24 is an anchor made of galvanised steel. The Index MTP-AT wedge anchor in the range of M8, M10, M12, M16 and M20 is an anchor made of zinc nickel steel. The Index MTP-G wedge anchor in the range of M8, M10, M12, M16 and M20 is an anchor made of sherardized steel. The Index MTP-X wedge anchor in the range of M8, M10, M12, M16 and M20 is an anchor made of galvanized steel. The Index MTP-A4 wedge anchor in the range of M8, M10, M12, M16 and M20 is an anchor made of stainless steel. The anchor is installed into a predrilled cylindrical hole and anchored by torque-controlled expansion. The anchorage is characterized by friction between expansion clip and concrete.

Product and installation descriptions are given in annexes A1 and A2.

### 2. Specification of the intended use in accordance with the applicable European Assessment Document.

The performances given in section 3 are only valid if the anchor is used in compliance with the specifications and conditions given in annex B.

The verifications and assessment methods on which this European Technical Assessment is based lead to the assumption of a working life of the anchor of at least 50 years. The indications given on the working life cannot be interpreted as a guarantee given by the producer but are to be regarded only as a mean to choosing the right products in relation to the expected economically reasonable working life of the works.

### 3. Performance of the product and references to the methods used for its assessment

#### 3.1 Mechanical resistance and stability (BWR 1)

Essential characteristic	Performance
Characteristic resistance to tension load (static and quasi-static loading), method A	See Annex C1, C3 and C4
Characteristic resistance to shear load (static and quasi-static loading).	See Annex C1 and C5
Displacements	See Annex C6
Characteristic resistance and displacements for seismic performance category C1 and C2	See Annex C7 to C10

#### 3.2 Safety in case of fire (BWR 2)

Essential characteristic	Performance
Reaction to fire	Anchorage satisfies requirements for class A1
Resistance to fire	See annexes C11 and C12



**4. Assessment and Verification of Constancy of Performances (hereinafter AVCP) system applied, with reference to its legal base**

The applicable European legal act for the system of Assessment and Verification of Constancy of Performances (see annex V to Regulation (EU) No 305/2011) is 96/582/EC.

The system to be applied is 1.

**5. Technical details necessary for the implementation of the AVCP system, as provided for in the applicable European Assessment Document.**

The technical details necessary for the implementation of the AVCP system are laid down in the quality plan deposited at Instituto de Ciencias de la Construcción Eduardo Torroja.



Instituto de Ciencias de la Construcción Eduardo Torroja  
CONSEJO SUPERIOR DE INVESTIGACIONES CIENTÍFICAS

C/ Serrano Galvache n.º 4. 28033 Madrid.  
Tel: (+34) 91 302 04 40  
<https://dit.ietcc.csic.es>



On behalf of the Instituto de Ciencias de la Construcción Eduardo Torroja  
Madrid, 26<sup>th</sup> of June 2024

Mr. Ángel Castillo Talavera  
Director IETcc - CSIC



**Product and installed condition**

MTP, MTP-AT, MTP-G, MTP-X. MTP-A4 anchor

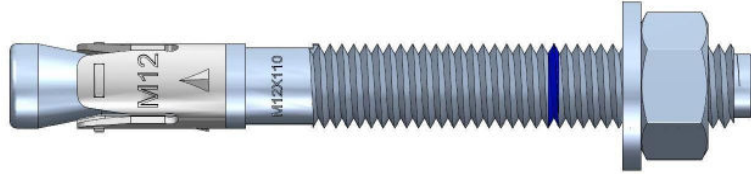

Identification on anchor:

- Expansion clip:
  - Anchor MTP: Company logo + “MTP” + Metric.
  - Anchor MTP-AT: Company logo + “MTP-AT” + Metric.
  - Anchor MTP-G: Company logo + “MTP-G” + Metric.
  - Anchor MTP-X: Company logo + “MTP-X” + Metric
  - Anchor MTP-A4: Company logo + “MTP-A4” + Metric
- Anchor body: Metric x Length
- Blue ring mark to show embedment depth
- Length letter code on head:

Letter on head	Length [mm]
C	68 ÷ 75
D	76 ÷ 88
E	89 ÷ 101
F	102 ÷ 113
G	114 ÷ 126
H	127 ÷ 139

Letter on head	Length [mm]
I	140 ÷ 151
J	152 ÷ 164
K	165 ÷ 177
L	178 ÷ 190
M	191 ÷ 202
N	203 ÷ 215

Letter on head	Length [mm]
O	216 ÷ 228
P	229 ÷ 240
Q	241 ÷ 253
R	254 ÷ 266
S	267 ÷ 300

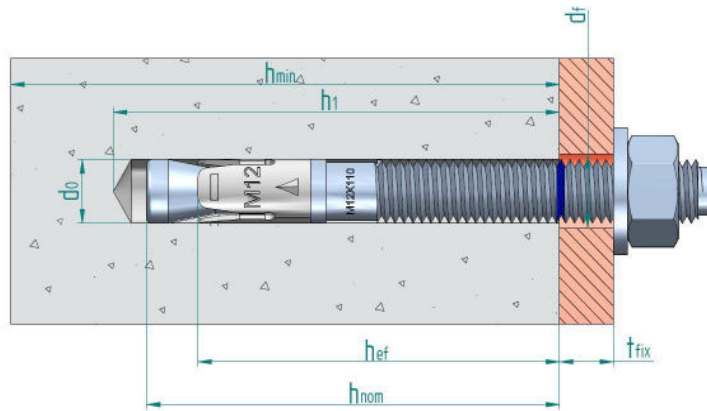

- d<sub>0</sub>: Nominal diameter of drill bit
- d<sub>f</sub>: Fixture clearance hole diameter
- h<sub>ef</sub>: Effective anchorage depth
- h<sub>1</sub>: Depth of drilled hole
- h<sub>nom</sub>: Overall anchor embedment depth in the concrete
- h<sub>min</sub>: Minimum thickness of concrete member
- t<sub>fix</sub>: Fixture thickness

**MTP anchors**

**Product description**

Installed condition

**Annex A1**

Código seguro de Verificación : GEN-54a0-5a64-7947-f2e5-0b5e-08a7-216e-eeef | Puede verificar la integridad de este documento en la siguiente dirección : <https://sede.administracion.gob.es/pagSedeFront/servicios/consultaCSV.htm>



**Table A1: materials**

Item	Designation	Material for MTP	Material for MTP-AT
1	Anchor body	M8 to M20: carbon steel wire rod, galvanized $\geq 5 \mu\text{m}$ ISO 4042 Zn5/An/T0 with antifriction coating M24: machined carbon steel, galvanized $\geq 5 \mu\text{m}$ ISO 4042 Zn5/An/T0 with antifriction coating	Carbon steel wire rod, zinc nickel $\geq 8 \mu\text{m}$ , sealed, ISO 4042 ZnNi8/An/T2, with antifriction coating
2	Washer	DIN 125, DIN 9021, DIN 440 galvanized $\geq 5 \mu\text{m}$ ISO 4042 Zn5/An/T0	DIN 125, DIN 9021 or DIN 440 zinc nickel $\geq 8 \mu\text{m}$ , sealed, ISO 4042 ZnNi8/An/T2
3	Nut	DIN 934 class 6, galvanized $\geq 5 \mu\text{m}$ ISO 4042 Zn5/An/T0	DIN 934 class 6 zinc nickel $\geq 8 \mu\text{m}$ , sealed, ISO 4042 ZnNi8/An/T2, class 6
4	Expansion clip	Stainless steel	Stainless steel

Item	Designation	Material for MTP-G	Material for MTP-X
1	Anchor body	Carbon steel wire rod, sherardized $\geq 40 \mu\text{m}$ EN 13811	Carbon steel wire rod, galvanized $\geq 5 \mu\text{m}$ ISO 4042 Zn5/An/T0 with antifriction coating
2	Washer	DIN 125, DIN 9021, DIN 440 sherardized $\geq 40 \mu\text{m}$ EN 13811	DIN 125, DIN 9021, DIN 440 galvanized $\geq 5 \mu\text{m}$ ISO 4042 Zn5/An/T0
3	Nut	DIN 934 class 6, sherardized $\geq 40 \mu\text{m}$ EN 13811	DIN 934 class 6 galvanized $\geq 5 \mu\text{m}$ ISO 4042 Zn5/An/T0
4	Expansion clip	Stainless steel	Carbon steel strip, sherardized $\geq 15 \mu\text{m}$ EN 13811

Item	Designation	Material for MTP-A4
1	Anchor body	Stainless steel, grade A4
2	Washer	DIN 125, DIN 9021, DIN 440 stainless steel, grade A4
3	Nut	Stainless steel, grade A4 with antifriction coating
4	Expansion clip	Stainless steel, grade A4, galvanized $\geq 5 \mu\text{m}$ ISO 4042 Zn5/An/T0

**MTP anchors**

**Product description**

**Materials**

**Annex A2**



**Specifications of intended use**

Version	Intended use	M8	M10	M12	M16	M20	M24
MTP	Static or quasi static loads	✓	✓	✓	✓	✓	✓
	Seismic loads category C1		✓	✓	✓		
	Seismic loads category C2			✓	✓		
	Resistance to fire exposure	✓	✓	✓	✓	✓	✓
MTP-AT	Static or quasi static loads	✓	✓	✓	✓	✓	
	Seismic loads category C1		✓	✓	✓		
	Seismic loads category C2			✓	✓		
	Resistance to fire exposure	✓	✓	✓	✓	✓	
MTP-G	Static or quasi static loads	✓	✓	✓	✓	✓	
	Seismic loads category C1	✓	✓	✓	✓	✓	
	Seismic loads category C2			✓	✓	✓	
	Resistance to fire exposure	✓	✓	✓	✓	✓	
MTP-X	Static or quasi static loads	✓	✓	✓	✓	✓	
	Seismic loads category C1	✓	✓	✓	✓	✓	
	Seismic loads category C2		✓	✓		✓	
	Resistance to fire exposure	✓	✓	✓	✓	✓	
MTP-A4	Static or quasi static loads	✓	✓	✓	✓	✓	
	Seismic loads category C1		✓	✓	✓	✓	
	Seismic loads category C2		✓	✓	✓	✓	
	Resistance to fire exposure	✓	✓	✓	✓	✓	

**Base materials:**

- Reinforced or unreinforced normal weight concrete without fibres according to EN 206:2013+A2:2021
- Strength classes C20/25 to C50/60 according to EN 206:2013+A2:2021
- Cracked or uncracked concrete

**Use conditions (environmental conditions):**

- Temperature range of the anchorage base material during the working life: -40 °C to +80 °C.
- MTP, MTP-AT, MTP-X: anchorages subjected to dry internal conditions.
- MTP-G:
  - Anchorages in cracked concrete: dry internal conditions
  - Anchorages in uncracked concrete: durability depending on the following environmental corrosivity categories according to ISO 9223:2012:

Corrosivity category	Corrosivity	Durability [years]
C1	Very low	50 <sup>1)</sup>
C2	Low	50 <sup>1)</sup>
C3	Medium	19
C4	High	9.5
C5	Very high	4.7
CX	Extreme	--

1) Working life of fastener limited to 50 years according to EAD 330232-01-0601 section 1.2.2

<b>MTP anchors</b>	<b>Annex B1</b>
<b>Intended use</b>	
Specifications	

Código seguro de Verificación : GEN-54a0-5a64-7947-f2e5-0b5e-08a7-216e-eeef | Puede verificar la integridad de este documento en la siguiente dirección : <https://sede.administracion.gob.es/pagSedeFront/servicios/consultaCSV.htm>



- MTP-A4: anchorages subjected to dry internal conditions, to external atmospheric exposure (including industrial and marine environment) or to permanent internal damp conditions if no particular aggressive conditions exist. Such particular aggressive conditions are e.g., permanent, alternating immersion in seawater or the splash zone of seawater, chloride atmosphere of indoor swimming pools or atmosphere with extreme chemical pollution (e.g., in desulphurization plants or road tunnels where de-icing materials are used). Atmospheres under Corrosion Resistance Class CRC III according to EN 1993-1-4:2006+A1:2015 annex A.

Corrosivity category	Corrosivity	Typical environments – Examples	
		Indoor	Outdoor
C1	Very low	Heated spaces with low relative humidity and insignificant pollution; e.g., offices, schools, museums.	Dry or cold zone, atmospheric environment with very low pollution and time of wetness; e.g., certain deserts, Central Arctic/Antarctic.
C2	Low	Unheated spaces with varying temperature and relative humidity. Low frequency of condensation and low pollution; e.g., storage, sport halls.	Temperate zone, atmospheric environment with low pollution ( $SO_2 < 5 \mu g/m^3$ ); e.g., rural areas, small towns. Dry or cold zone, atmospheric environment with short time or wetness, e.g., deserts, subarctic areas.
C3	Medium	Spaces with moderate frequency of condensation and moderate pollution from production process; e.g., food-processing plants, laundries, breweries, dairies.	Temperate zone, atmospheric environment with medium pollution ( $SO_2 5 \mu g/m^3$ to $30 \mu g/m^3$ ), or some effect of chlorides, e.g., urban areas, coastal areas with low deposition of chlorides. Subtropical and tropical zone, atmosphere with low pollution.
C4	High	Spaces with high frequency of condensation and high pollution from production process; e.g., industrial processing plants.	Temperate zone, atmospheric environment with high pollution ( $SO_2 30 \mu g/m^3$ to $90 \mu g/m^3$ ), or substantial effect of chlorides; e.g., polluted urban areas, industrial areas, coastal areas without spray of salt water or exposure to strong effect of de-icing salts. Subtropical and tropical zone, atmosphere with medium pollution.
C5	Very High	Spaces with very high frequency of condensation and/or high pollution from production process; e.g., mines, caverns for industrial purposes, unventilated sheds in subtropical and tropical zones	Temperate zone, atmospheric environment with very high pollution ( $SO_2 90 \mu g/m^3$ to $250 \mu g/m^3$ ), or significant effect of chlorides; e.g., industrial areas, coastal areas, sheltered positions on coastline. Subtropical and tropical zone, atmosphere with medium pollution.
CX	Extreme	Spaces with almost permanent condensation or extensive periods of exposure to extreme humidity effects and/or high pollution from production process; e.g., unventilated sheds in humid tropical zones with penetration of outdoor pollution including airborne chlorides and corrosion-stimulating particulate matter	Subtropical and tropical zone (very high time of wetness), atmospheric environment with very high $SO_2$ pollution (higher than $250 \mu g/m^3$ ) including accompanying and production factors and/or strong effect of chlorides; e.g., extreme industrial areas, coastal and offshore areas, occasional contact with salt spray.

**Design:**

- Anchorages are designed under the responsibility of an engineer experienced in anchorages and concrete.
- Verifiable calculation rules and drawings are prepared taking into account of the loads to be anchored. The position of the anchor is indicated on the design drawings (e.g. position of the anchor relative to reinforcement or to supports, etc.).
- Anchorages under static or quasi-static actions are designed for design method A in accordance with EN 1992-4:2018
- Anchorages under seismic actions are designed in accordance with EN 1992-4:2018. Anchorages shall be positioned outside of critical regions (e.g. plastic hinges) of the concrete structure. Fastening in stand-off installation or with grout layer are not allowed.
- Anchorages under fire exposure are designed in accordance with EN 1992-4:2018. It must be ensured that local spalling of the concrete cover does not occur.

<b>MTP anchors</b>	<b>Annex B2</b>
<b>Intended use</b>	
<b>Specifications</b>	

Código seguro de Verificación : GEN-54a0-5a64-7947-f2e5-0b5e-08a7-216e-eeef | Puede verificar la integridad de este documento en la siguiente dirección : <https://sede.administracion.gob.es/pagSedeFront/servicios/consultaCSV.htm>





**Installation:**

- Hole drilling by rotary plus hammer mode.
- Anchor installation carried out by appropriately qualified personal and under the supervision of the person responsible for technical matters of the site.

In case of aborted hole: new drilling at a minimum distance away of twice the depth of aborted hole or smaller distance if the aborted hole is filled with high strength mortar and if under shear or oblique tension load it is not the direction of the load application.

Código seguro de Verificación : GEN-54a0-5a64-7947-f2e5-0b5e-08a7-216e-eeef | Puede verificar la integridad de este documento en la siguiente dirección :  
<https://sede.administracion.gob.es/pagSedeFront/servicios/consultaCSV.htm>

<b>MTP anchors</b>	<b>Annex B3</b>
<b>Intended use</b>	
Specifications	



**Table C1: Installation parameters for MTP, MTP-AT, MTP-G, MTP-X anchors**

Installation parameters			Performances					
			M8	M10	M12	M16	M20	M24
d <sub>0</sub>	Nominal diameter of drill bit:	[mm]	8	10	12	16	20	24
d <sub>f</sub>	Fixture clearance hole diameter:	[mm]	9	12	14	18	22	26
T <sub>inst</sub>	Nominal installation torque:	[Nm]	20 / 15 <sup>1)</sup>	40	60	100	200	250
L <sub>min</sub>	Minimum total length of the bolt:	[mm]	68	82	98	119	140	175
h <sub>1</sub>	Depth of drilled hole:	[mm]	60	75	85	105	125	155
h <sub>nom</sub>	Overall anchor embedment depth in the concrete:	[mm]	55	68	80	97	114	143
h <sub>ef</sub>	Effective anchorage depth:	[mm]	48	60	70	85	100	125
t <sub>fix</sub>	Thickness of fixture for washer DIN 125 ≤ <sup>2)</sup>	[mm]	L - 66	L - 80	L - 96	L - 117	L - 138	L - 170
t <sub>fix</sub>	Thickness of fixture for washers DIN 9021, DIN 440 ≤ <sup>2)</sup>	[mm]	L - 67	L - 81	L - 97	L - 118	L - 139	L - 171
s <sub>min</sub>	Minimum allowable spacing:	[mm]	40	40	60	65	95	125
	for edge distance c ≥	[mm]	55	70	75	95	105	125
c <sub>min</sub>	Minimum allowable distance:	[mm]	45	45	55	70	95	125
	for spacing s ≥	[mm]	55	90	110	115	105	125
h <sub>min</sub>	Minimum thickness of concrete member: MTP, MTP-AT, MTP-G	[mm]	100	120	140	170	200	250
h <sub>min</sub>	Minimum thickness of concrete member: MTP-X	[mm]	80	90	105	130	150	--

<sup>1)</sup> Respective values for anchors MTP, MTP-AT / MTP-G, MTP-X

<sup>2)</sup> L = total anchor length,

**Table C2: Installation parameters for MTP-A4 anchor**

Installation parameters			Performances				
			M8	M10	M12	M16	M20
d <sub>0</sub>	Nominal diameter of drill bit:	[mm]	8	10	12	16	20
d <sub>f</sub>	Fixture clearance hole diameter:	[mm]	9	12	14	18	22
T <sub>inst</sub>	Nominal installation torque:	[Nm]	15	30	60	100	200
L <sub>min</sub>	Minimum total length of the bolt:	[mm]	68	82	98	119	140
h <sub>1</sub>	Depth of drilled hole:	[mm]	60	75	85	105	125
h <sub>nom</sub>	Overall anchor embedment depth in the concrete:	[mm]	55	68	80	97	114
h <sub>ef</sub>	Effective anchorage depth:	[mm]	48	60	70	85	100
t <sub>fix</sub>	Thickness of fixture for washer DIN 125 ≤ <sup>1)</sup>	[mm]	L - 66	L - 80	L - 96	L - 117	L - 138
t <sub>fix</sub>	Thickness of fixture for washers DIN 9021, DIN 440 ≤ <sup>1)</sup>	[mm]	L - 67	L - 81	L - 97	L - 118	L - 139
s <sub>min</sub>	Minimum allowable spacing:	[mm]	42	47	57	75	100
c <sub>min</sub>	Minimum allowable distance:	[mm]	47	52	62	75	90
h <sub>min</sub>	Minimum thickness of concrete member:	[mm]	100	120	140	170	200

<sup>1)</sup> L = total anchor length

<b>MTP anchors</b>	<b>Annex C1</b>
<b>Performances</b>	
Installation parameters	



### Installation process

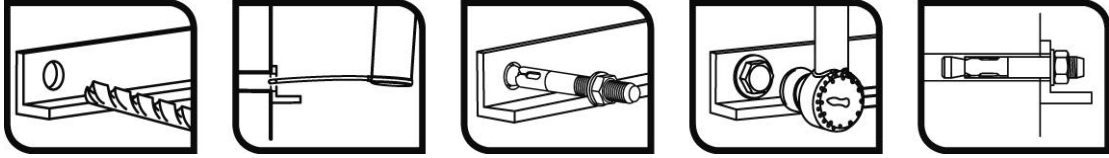

Código seguro de Verificación : GEN-54a0-5a64-7947-f2e5-0b5e-08a7-216e-eeef | Puede verificar la integridad de este documento en la siguiente dirección :  
<https://sede.administracion.gob.es/pagSedeFront/servicios/consultaCSV.htm>

**MTP anchors**

**Performances**

Installation procedure

**Annex C2**



**Table C3: Essential characteristics under static or quasi-static tension loads according to design method A according to EN 1992-4 for MTP, MTP-AT, MTP-G, MTP-X anchors**

Essential characteristics under static or quasi-static tension loads according to design method A		Performances							
		M8	M10	M12	M16	M20	M24		
<b>Tension loads: steel failure</b>									
$N_{Rk,s}$	Characteristic resistance:	[kN]	18.1	31.4	40.4	72.7	116.6	179.2	
$\gamma_{Ms}$	Partial safety factor: <sup>1)</sup>	[-]	1.5	1.5	1.5	1.5	1.5	1.5	
<b>Tension loads: pull-out failure in concrete</b>									
<b>MTP, MTP-AT anchor</b>									
$N_{Rk,p,ucr}$	Characteristic resistance in C20/25 uncracked concrete:	[kN]	9	18	20	36	48	55	
$N_{Rk,p,cr}$	Characteristic resistance in C20/25 cracked concrete:	[kN]	5	9.5	12	25	32	35	
<b>MTP-G anchor</b>									
$N_{Rk,p,ucr}$	Characteristic resistance in C20/25 uncracked concrete:	[kN]	10	18	$\geq N_{Rk,c}^{(2)}$	36	$\geq N_{Rk,c}^{(2)}$	--	
$N_{Rk,p,cr}$	Characteristic resistance in C20/25 cracked concrete:	[kN]	6	10	16	$\geq N_{Rk,c}^{(2)}$	30	--	
<b>MTP-X anchor</b>									
$N_{Rk,p,ucr}$	Characteristic resistance in C20/25 uncracked concrete:	[kN]	10	18	28	34	$\geq N_{Rk,c}^{(2)}$	--	
$N_{Rk,p,cr}$	Characteristic resistance in C20/25 cracked concrete:	[kN]	7	11	15	$\geq N_{Rk,c}^{(2)}$	$\geq N_{Rk,c}^{(2)}$	--	
$\gamma_{ins}$	Installation safety factor:	[-]	1.2	1.0	1.0	1.0	1.0	1.2	
$\psi_c$	Increasing factor for $N_{Rk,p}^0$ :	C30/37	[-]	1.22	1.17	1.22	1.22	1.17	1.22
		C40/50	[-]	1.41	1.31	1.41	1.41	1.31	1.41
		C50/60	[-]	1.58	1.43	1.58	1.58	1.43	1.58
<b>Tension loads: concrete cone and splitting failure</b>									
$h_{ef}$	Effective embedment depth:	[mm]	48	60	70	85	100	125	
$k_{ucr,N}$	Factor for uncracked concrete:	[-]	11.0						
$k_{cr,N}$	Factor for cracked concrete:	[-]	7.7						
$\gamma_{ins}$	Installation safety factor:	[-]	1.2	1.0	1.0	1.0	1.0	1.2	
$s_{cr,N}$	Concrete cone failure:	[mm]	$3 \times h_{ef}$						
$c_{cr,N}$		[mm]	$1.5 \times h_{ef}$						
$s_{cr,sp}$	Splitting failure:	[mm]	288	300	350	425 / 510 <sup>3)</sup>	500 / 600 <sup>3)</sup>	560	
$c_{cr,sp}$		[mm]	144	150	175	213 / 255 <sup>3)</sup>	250 / 300 <sup>3)</sup>	280	

- 1) In absence of other national regulations
- 2) Pull out failure is not decisive.  $N_{Rk,c}^0$  calculated according to EN 1992-4
- 3) Respective values for anchors MTP, MTP-AT / MTP-G, MTP-X

**MTP anchors**

**Performances**

Essential characteristics under static or quasi-static tension loads

**Annex C3**



English translation prepared by IETcc

**Table C4: Essential characteristics under static or quasi-static tension loads according to design method A according to EN 1992-4 for MTP-A4 anchor**

Essential characteristics under static or quasi-static tension loads according to design method A			Performances					
			M8	M10	M12	M16	M20	
<b>Tension loads: steel failure</b>								
$N_{Rk,s}$	Characteristic resistance:	[kN]	18.5	30.9	45.5	71.5	122.5	
$\gamma_{Ms}$	Partial safety factor <sup>1)</sup> :	[-]	1.4	1.4	1.4	1.4	1.4	
<b>Tension loads: pull-out failure in concrete</b>								
$N_{Rk,p,ucr}$	Characteristic resistance in C20/25 uncracked concrete:	[kN]	12	16	22	$\geq N_{Rk,c}^{(2)}$	$\geq N_{Rk,c}^{(2)}$	
$\psi_c$	Increasing factor for $N_{Rk,p}^0$ :	C30/37	[-]	1.22	1.22	1.22	1.22	1.09
		C40/50	[-]	1.41	1.41	1.41	1.41	1.16
		C50/60	[-]	1.58	1.58	1.58	1.58	1.22
$N_{Rk,p,cr}$	Characteristic resistance in C20/25 cracked concrete:	[kN]	8.5	14	19	$\geq N_{Rk,c}^{(2)}$	$\geq N_{Rk,c}^{(2)}$	
$\psi_c$	Increasing factor for $N_{Rk,p}^0$ :	C30/37	[-]	1.01	1.00	1.09	1.09	1.17
		C40/50	[-]	1.02	1.00	1.15	1.16	1.32
		C50/60	[-]	1.02	1.00	1.20	1.22	1.44
$\gamma_{ins}$	Installation safety factor:	[-]	1.0	1.0	1.2	1.2	1.2	
<b>Tension loads: concrete cone and splitting failure</b>								
$h_{ef}$	Effective embedment depth:	[mm]	48	60	70	85	100	
$k_{ucr,N}$	Factor for uncracked concrete:	[-]	11.0					
$k_{cr,N}$	Factor for cracked concrete:	[-]	7,7					
$\gamma_{ins}$	Installation safety factor:	[-]	1.0	1.0	1.2	1.2	1.2	
$s_{cr,N}$	Concrete cone failure:	[mm]	3 x $h_{ef}$					
$c_{cr,N}$		[mm]	1.5 x $h_{ef}$					
$s_{cr,sp}$	Splitting failure:	[mm]	164	204	238	290	380	
$c_{cr,sp}$		[mm]	82	102	119	145	190	

- 1) In absence of other national regulations
- 2) Pull out failure is not decisive.  $N_{Rk,c}^0$  calculated according to EN 1992-4

<b>MTP anchors</b>	<b>Annex C4</b>
<b>Performances</b>	
Essential characteristics under static or quasi-static tension loads	

Código seguro de Verificación : GEN-54a0-5a64-7947-f2e5-0b5e-08a7-216e-eeef | Puede verificar la integridad de este documento en la siguiente dirección : <https://sede.administracion.gob.es/pagSedeFront/servicios/consultaCSV.htm>



English translation prepared by IETcc

**Table C5: Essential characteristics under static or quasi-static shear loads of design method A according to EN 1992-4 for MTP, MTP-AT, MTP-G, MTP-X anchors**

Essential characteristics under static or quasi-static shear loads according to design method A			Performances					
			M8	M10	M12	M16	M20	M24
<b>Shear loads: steel failure without lever arm</b>								
$V_{Rk,s}$	Characteristic resistance:	[kN]	11.0	17.4	25.3	47.1	73.1	84.7
$k_7$	Ductility factor:	[-]	1.00					
$\gamma_{Ms}$	Partial safety factor <sup>1)</sup> :	[-]	1.25	1.25	1.25	1.25	1.25	1.25
<b>Shear loads: steel failure with lever arm</b>								
$M^0_{Rk,s}$	Characteristic bending moment:	[Nm]	22.5	44.8	78.6	199.8	389.4	673.5
$\gamma_{Ms}$	Partial safety factor:	[-]	1.25	1.25	1.25	1.25	1.25	1.25
<b>Shear loads: concrete pryout failure</b>								
$k_8$	Pryout factor:	[-]	1	2	2	2	2	2
$\gamma_{ins}$	Installation safety factor:	[-]	1.00					
<b>Shear loads: concrete edge failure</b>								
$l_f$	Effective length of anchor under shear loads:	[mm]	48	60	70	85	100	125
$d_{nom}$	Outside anchor diameter:	[mm]	8	10	12	16	20	24
$\gamma_{ins}$	Installation safety factor:	[-]	1.00					

1) In absence of other national regulations

**Table C6 Essential characteristics under static or quasi-static shear loads of design method A according to EN 1992-4 for MTP-A4 anchor**

Essential characteristics under static or quasi-static shear loads according to design method A			Performances				
			M8	M10	M12	M16	M20
<b>Shear loads: steel failure without lever arm</b>							
$V_{Rk,s}$	Characteristic resistance:	[kN]	11.9	18.9	27.4	55.0	85.9
$k_7$	Ductility factor:	[-]	1.00				
$\gamma_{Ms}$	Partial safety factor <sup>1)</sup> :	[-]	1.25	1.25	1.25	1.25	1.25
<b>Shear loads: steel failure with lever arm</b>							
$M^0_{Rk,s}$	Characteristic bending moment:	[Nm]	26.2	52.3	91.7	233.1	454.3
$\gamma_{Ms}$	Partial safety factor:	[-]	1.25	1.25	1.25	1.25	1.25
<b>Shear loads: concrete pryout failure</b>							
$k_8$	Pryout factor:	[-]	1	2	2	2	2
$\gamma_{ins}$	Installation safety factor:	[-]	1.00				
<b>Shear loads: concrete edge failure</b>							
$l_f$	Effective length of anchor under shear loads:	[mm]	48	60	70	85	100
$d_{nom}$	Outside anchor diameter:	[mm]	8	10	12	16	20
$\gamma_{ins}$	Installation safety factor:	[-]	1.00				

1) In absence of other national regulations

**MTP anchors**

**Performances**

Essential characteristics under static or quasi-static shear loads

**Annex C5**

Código seguro de Verificación : GEN-54a0-5a64-7947-f2e5-0b5e-08a7-216e-eeef | Puede verificar la integridad de este documento en la siguiente dirección : <https://sede.administracion.gob.es/pagSedeFront/servicios/consultaCSV.htm>



**Table C7: Displacements under tension loads for MTP, MTP-AT, MTP-G, MTP-X, MTP-A4 anchors**

Displacements under tension loads			Performances					
			M8	M10	M12	M16	M20	M24
<b>MTP, MTP-AT anchor</b>								
N	Service tension load:	[kN]	2.5	4.3	6.3	10.4	13.9	18.0
$\delta_{N0}$	Short term displacement:	[mm]	1.1	0.7	1.0	0.4	1.6	0.4
$\delta_{N\infty}$	Long term displacement:	[mm]	1.9	1.9	1.9	1.9	1.9	2.0
<b>MTP-G anchor</b>								
N	Service tension load:	[kN]	2.5	4.3	6.3	10.4	13.9	--
$\delta_{N0}$	Short term displacement:	[mm]	1.0	1.1	0.9	1.5	1.2	--
$\delta_{N\infty}$	Long term displacement:	[mm]	1.9	1.9	1.9	1.9	1.9	--
<b>MTP-X anchor</b>								
N	Service tension load:	[kN]	2.5	4.3	7.6	11.9	14.3	--
$\delta_{N0}$	Short term displacement:	[mm]	1.0	1.1	0.9	1.5	1.3	--
$\delta_{N\infty}$	Long term displacement:	[mm]	1.6	1.6	1.6	1.6	1.6	--
<b>MTP-A4 anchor</b>								
N	Service tension load in non cracked concrete:	[kN]	5.7	7.6	8.7	15.3	19.5	--
$\delta_{N0}$	Short term displacement:	[mm]	1.4	1.4	1.4	1.8	1.8	--
$\delta_{N\infty}$	Long term displacement:	[mm]	1.9	1.9	1.9	1.9	1.9	--
<b>MTP-A4 anchor</b>								
N	Service tension load in cracked concrete:	[kN]	4.0	6.7	7.5	10.7	13.7	--
$\delta_{N0}$	Short term displacement:	[mm]	1.2	1.3	1.3	1.3	1.3	--
$\delta_{N\infty}$	Long term displacement:	[mm]	1.7	1.7	1.7	1.7	1.7	--

**Table C8: Displacements under shear load for MTP, MTP-AT, MTP-G, MTP-X, MTP-A4 anchors**

Displacements under shear loads			Performances					
			M8	M10	M12	M16	M20	M24
<b>MTP, MTP-AT anchor</b>								
V	Service shear load:	[kN]	4.9	6.8	8.5	15.1	24.6	33.6
$\delta_{V0}$	Short term displacement:	[mm]	1.0	1.5	1.8	1.9	3.1	1.4
$\delta_{V\infty}$	Long term displacement:	[mm]	1.5	2.3	2.7	2.9	4.7	2.1
<b>MTP-G anchor</b>								
V	Service shear load:	[kN]	4.9	6.8	8.5	15.1	24.6	-
$\delta_{V0}$	Short term displacement:	[mm]	1.0	1.5	1.8	1.9	3.1	--
$\delta_{V\infty}$	Long term displacement:	[mm]	1.5	2.3	2.7	2.9	4.7	--
<b>MTP-X anchor</b>								
V	Service shear load:	[kN]	4.9	6.8	8.5	15.1	24.6	--
$\delta_{V0}$	Short term displacement:	[mm]	1.0	1.5	1.8	1.9	3.1	--
$\delta_{V\infty}$	Long term displacement:	[mm]	1.5	2.3	2.7	2.9	4.7	--
<b>MTP-A4 anchor</b>								
V	Service shear load:	[kN]	6.8	10.8	15.7	31.4	46.9	--
$\delta_{V0}$	Short term displacement:	[mm]	1.9	1.6	1.6	2.2	2.2	--
$\delta_{V\infty}$	Long term displacement:	[mm]	2.4	2.4	2.4	3.3	3.3	--

**MTP anchors**

**Performances**

Displacements under static or quasi-static tension and shear loads

**Annex C6**



**Table C9: Essential characteristics for seismic performance category C1 MTP, MTP-AT, MTP-G, MTP-X anchors**

Essential characteristics for seismic performance category C1			Performances					
			M8	M10	M12	M16	M20	M24
<b>Steel tension failure</b>								
$N_{Rk,s,C1}$	Characteristic tension steel failure:	[kN]	18.1	31.4	40.4	72.7	116.6	--
$\gamma_{Ms,N}$	Partial safety factor:	[-]	1.5	1.5	1.5	1.5	1.5	--
<b>Steel shear failure</b>								
<b>MTP, MTP-AT anchor</b>								
$V_{Rk,s,C1}$	Characteristic shear steel failure:	[kN]	--	12.2	17.8	33.0	--	--
<b>MTP-G anchor</b>								
$V_{Rk,s,C1}$	Characteristic shear steel failure:	[kN]	6.6	12.5	18.9	35.4	54.8	--
<b>MTP-X anchor</b>								
$V_{Rk,s,C1}$	Characteristic shear steel failure:	[kN]	7.7	12.2	17.8	33.0	58.5	--
$\alpha_{gap}$	Factor for annular gap:	[-]	0.5			--		
$\gamma_{Ms,V}$	Partial safety factor:	[-]	1.25	1.25	1.25	1.25	1.25	--
<b>Pull out failure</b>								
<b>MTP, MTP-AT anchor</b>								
$N_{Rk,p,C1}$	Characteristic pull out failure:	[kN]	--	5.3	8.4	17.5	--	--
<b>MTP-G anchor</b>								
$N_{Rk,p,C1}$	Characteristic pull out failure:	[kN]	6.0	9.0	16.0	25.0	30.0	--
<b>MTP-X anchor</b>								
$N_{Rk,p,C1}$	Characteristic pull out failure:	[kN]	5.9	8.9	16.0	25.0	30.0	--
$\gamma_{ins}$	Installation safety factor:	[-]	1.2	1.0	1.0	1.0	1.0	--
<b>Concrete cone failure</b>								
$h_{ef}$	Effective embedment depth:	[mm]	48	60	70	85	100	--
$s_{cr,N}$	Spacing:	[mm]	3 x $h_{ef}$			--		
$c_{cr,N}$	Edge distance:	[mm]	1.5 x $h_{ef}$			--		
$\gamma_{ins}$	Installation safety factor:	[-]	1.2	1.0	1.0	1.0	1.0	--
<b>Concrete pryout failure</b>								
$k_8$	Pryout factor:	[-]	1	2	2	2	2	--
<b>Concrete edge failure</b>								
$l_f$	Effective length of anchor:	[mm]	48	60	70	85	100	--
$d_{nom}$	Outside anchor diameter:	[-]	8	10	12	16	20	--

MTP anchors

Performances

Essential characteristics for seismic performance category C1

Annex C7





**Table C10: Essential characteristics for seismic performance category C1 MTP-A4 anchors**

Essential characteristics for seismic performance category C1			Performances				
			M8	M10	M12	M16	M20
<b>Steel tension failure</b>							
$N_{Rk,s,C1}$	Characteristic tension steel failure:	[kN]	--	30.9	45.5	71.5	122.5
$\gamma_{Ms,N}$	Partial safety factor:	[-]	--	1.4	1.4	1.4	1.4
<b>Steel shear failure</b>							
$V_{Rk,s,C1}$	Characteristic shear steel failure:	[kN]	--	10.6	19.2	40.2	45.5
$\alpha_{gap}$	Factor for annular gap:	[-]	--	0.5			
$\gamma_{Ms,V}$	Partial safety factor:	[-]	--	1.25	1.25	1.25	1.25
<b>Pull out failure</b>							
$N_{Rk,p,C1}$	Characteristic pull out failure:	[kN]	--	6.4	11.8	17.5	20.6
$\gamma_{ins}$	Installation safety factor:	[-]	--	1.0	1.2	1.2	1.2
<b>Concrete cone failure</b>							
$h_{ef}$	Effective embedment depth:	[mm]	--	60	70	85	100
$s_{cr,N}$	Spacing:	[mm]	--	3 x $h_{ef}$			
$c_{cr,N}$	Edge distance:	[mm]	--	1.5 x $h_{ef}$			
$\gamma_{ins}$	Installation safety factor:	[-]	--	1.0	1.2	1.2	1.2
<b>Concrete pryout failure</b>							
$k_8$	Pryout factor:	[-]	--	2	2	2	2
<b>Concrete edge failure</b>							
$l_f$	Effective length of anchor:	[mm]	--	60	70	85	100
$d_{nom}$	Outside anchor diameter:	[-]	--	10	12	16	20

MTP anchors

Performances

Essential characteristics for seismic performance category C1

Annex C8

Código seguro de Verificación : GEN-54a0-5a64-7947-f2e5-0b5e-08a7-216e-eeef | Puede verificar la integridad de este documento en la siguiente dirección : <https://sede.administracion.gob.es/pagSedeFront/servicios/consultaCSV.htm>



**Table C11: Essential characteristics for seismic performance category C2 MTP, MTP-AT, MTP-G, MTP-X anchors**

Essential characteristics for seismic performance category C2			Performances					
			M8	M10	M12	M16	M20	M24
<b>Steel tension and shear failure</b>								
$N_{Rk,s,C2}$	Characteristic tension steel failure:	[kN]	--	31.4	40.4	72.7	116.6	--
$\gamma_{Ms,N}$	Partial safety factor:	[-]	--	1.5	1.5	1.5	1.5	--
$V_{Rk,s,C2}$	Characteristic shear steel failure:	[kN]	--	12.2	17.8	33.0	58.5	--
$\alpha_{gap}$	Factor for annular gap	[-]	--	0.5	0.5	0.5	0.5	--
$\gamma_{Ms,V}$	Partial safety factor:	[-]	--	1.25	1.25	1.25	1.25	--
<b>Pull out failure</b>								
<b>MTP, MTP-AT anchor</b>								
$N_{Rk,p,C2}$	Characteristic pull out failure:	[kN]	--	--	5.2	8.9	--	--
<b>MTP-G anchor</b>								
$N_{Rk,p,C2}$	Characteristic pull out failure:	[kN]	--	--	5.9	16.3	17.2	--
<b>MTP-X anchor</b>								
$N_{Rk,p,C2}$	Characteristic pull out failure:	[kN]	--	3.9	9.1	--	21.0	--
$\gamma_{ins}$	Installation safety factor:	[-]	--	1.0	1.0	1.0	1.0	--
<b>Concrete cone failure</b>								
$h_{ef}$	Effective embedment depth:	[mm]	--	60	70	85	100	--
$s_{cr,N}$	Spacing:	[mm]	--	3 x $h_{ef}$				--
$c_{cr,N}$	Edge distance:	[mm]	--	1.5 x $h_{ef}$				--
$\gamma_{ins}$	Installation safety factor:	[-]	--	1.0	1.0	1.0	1.0	--
<b>Concrete pryout failure</b>								
$k_8$	Pryout factor:	[-]	--	2	2	2	2	--
<b>Concrete edge failure</b>								
$l_f$	Effective length of anchor:	[mm]	--	60	70	85	100	--
$d_{nom}$	Outside anchor diameter:	[-]	--	10	12	16	20	--
<b>Displacements</b>								
<b>MTP, MTP-AT anchor</b>								
$\bar{\delta}_{N,C2} (DLS)$	Displacement Damage	[mm]	--	--	2.34	3.99	--	--
$\bar{\delta}_{V,C2} (DLS)$	Limitation State: <sup>1) 2)</sup>	[mm]	--	--	5.53	5.96	--	--
$\bar{\delta}_{N,C2} (ULS)$	Displacement Ultimate Limit	[mm]	--	--	9.54	10.17	--	--
$\bar{\delta}_{V,C2} (ULS)$	State: <sup>1)</sup>	[mm]	--	--	9.08	10.66	--	--
<b>MTP-G anchor</b>								
$\bar{\delta}_{N,C2} (DLS)$	Displacement Damage	[mm]	--	--	6.79	5.21	5.72	--
$\bar{\delta}_{V,C2} (DLS)$	Limitation State: <sup>1) 2)</sup>	[mm]	--	--	5.53	5.96	6.37	--
$\bar{\delta}_{N,C2} (ULS)$	Displacement Ultimate Limit	[mm]	--	--	24.70	19.58	17.20	--
$\bar{\delta}_{V,C2} (ULS)$	State: <sup>1)</sup>	[mm]	--	--	9.08	10.66	12.32	--
<b>MTP-X anchor</b>								
$\bar{\delta}_{N,C2} (DLS)$	Displacement Damage	[mm]	--	3.15	5.57	--	6.82	--
$\bar{\delta}_{V,C2} (DLS)$	Limitation State: <sup>1) 2)</sup>	[mm]	--	5.61	5.53	--	6.37	--
$\bar{\delta}_{N,C2} (ULS)$	Displacement Ultimate Limit	[mm]	--	14.77	20.31	--	29.12	--
$\bar{\delta}_{V,C2} (ULS)$	State: <sup>1)</sup>	[mm]	--	8.68	9.08	--	12.32	--

<sup>1)</sup> The listed displacements represent mean values

<sup>2)</sup> A small displacement may be required in the design in the case of displacements sensitive fastening of "rigid" supports. The characteristics resistance associated with such small displacements may be determined by linear interpolation or proportional reduction.

**MTP anchors**

**Performances**

Essential characteristics for seismic performance category C2

**Annex C9**



**Table C12: Essential characteristics for seismic performance category C2 MTP-A4 anchors**

Essential characteristics for seismic performance category C2			Performances				
			M8	M10	M12	M16	M20
<b>Steel tension and shear failure</b>							
$N_{Rk,s,C2}$	Characteristic tension steel failure:	[kN]	--	30.9	45.5	71.5	122.5
$\gamma_{Ms,N}$	Partial safety factor:	[-]	--	1.4	1.4	1.4	1.4
$V_{Rk,s,C2}$	Characteristic shear steel failure:	[kN]	--	10.6	19.2	40.2	45.5
$\alpha_{gap}$	Factor for annular gap	[-]	--	0.5	0.5	0.5	0.5
$\gamma_{Ms,V}$	Partial safety factor:	[-]	--	1.25	1.25	1.25	1.25
<b>Pull out failure</b>							
$N_{Rk,p,C2}$	Characteristic pull out failure:	[kN]	--	3.0	4.0	15.8	15.7
$\gamma_{ins}$	Installation safety factor:	[-]	--	1.0	1.2	1.2	1.2
<b>Concrete cone failure</b>							
$h_{ef}$	Effective embedment depth:	[mm]	--	60	70	85	100
$s_{cr,N}$	Spacing:	[mm]	--	3 x $h_{ef}$			
$c_{cr,N}$	Edge distance:	[mm]	--	1.5 x $h_{ef}$			
$\gamma_{ins}$	Installation safety factor:	[-]	--	1.0	1.2	1.2	1.2
<b>Concrete pryout failure</b>							
$k_8$	Pryout factor:	[-]	--	2	2	2	2
<b>Concrete edge failure</b>							
$l_f$	Effective length of anchor:	[mm]	--	60	70	85	100
$d_{nom}$	Outside anchor diameter:	[-]	--	10	12	16	20
<b>Displacements</b>							
$\delta_{N,C2}$ (DLS)	Displacement Damage	[mm]	--	2.6	4.9	5.2	5.5
$\delta_{V,C2}$ (DLS)	Limitation State: <sup>1) 2)</sup>	[mm]	--	4.5	4.5	5.2	5.6
$\delta_{N,C2}$ (ULS)	Displacement Ultimate Limit	[mm]	--	9.3	15.2	13.2	15.7
$\delta_{V,C2}$ (ULS)	State: <sup>1)</sup>	[mm]	--	6.9	7.2	8.3	7.9

<sup>1)</sup> The listed displacements represent mean values

<sup>2)</sup> A small displacement may be required in the design in the case of displacements sensitive fastening of "rigid" supports. The characteristics resistance associated with such small displacements may be determined by linear interpolation or proportional reduction.

MTP anchors

Performances

Essential characteristics for seismic performance category C2

Annex C10



**Table C13: Essential characteristics under fire exposure MTP, MTP-AT, MTP-G, MTP-X anchors**

Essential characteristics under fire exposure			Performances					
			M8	M10	M12	M16	M20	M24
<b>Steel failure</b>								
$N_{Rk,s,fi}$	Characteristic tension resistance:	R30 [kN]	0,4	0,9	1,7	3,1	4,9	7,1
		R60 [kN]	0,3	0,8	1,3	2,4	3,7	5,3
		R90 [kN]	0,3	0,6	1,1	2,0	3,2	4,6
		R120 [kN]	0,2	0,5	0,8	1,6	2,5	3,5
$V_{Rk,s,fi}$	Characteristic shear resistance:	R30 [kN]	0,4	0,9	1,7	3,1	4,9	7,1
		R60 [kN]	0,3	0,8	1,3	2,4	3,7	5,3
		R90 [kN]	0,3	0,6	1,1	2,0	3,2	4,5
		R120 [kN]	0,2	0,5	0,8	1,6	2,5	3,5
$M^0_{Rk,s,fi}$	Characteristic bending resistance:	R30 [Nm]	0,4	1,1	2,6	6,7	13,0	22,5
		R60 [Nm]	0,3	1,0	2,0	5,0	9,7	16,8
		R90 [Nm]	0,3	0,7	1,7	4,3	8,4	14,6
		R120 [Nm]	0,2	0,6	1,3	3,3	6,5	11,2
<b>Pull out failure</b>								
$N_{Rk,p,fi}$	Characteristic resistance:	R30 [kN]	1,3/1,5 <sup>3)</sup>	2,3	3,0/4,0 <sup>3)</sup>	6,3	7,5	7,5
		R60 [kN]						
		R90 [kN]						
		R120 [kN]	1,0/1,2 <sup>3)</sup>	1,8	2,4/3,2 <sup>3)</sup>	5,0	6,0	6,0
<b>Concrete cone failure <sup>2)</sup></b>								
$N_{Rk,c,fi}$	Characteristic resistance:	R30 [kN]	2,9	5,0	7,4	12,0	18,0	31,4
		R60 [kN]						
		R90 [kN]						
		R120 [kN]	2,3	4,0	5,9	9,6	14,4	25,2
$s_{cr,fi}$	Critical spacing:	R30 to R120 [mm]	4 x $h_{ef}$					
$s_{min,fi}$	Minimum spacing:	R30 to R120 [mm]	50	60	70	85/128 <sup>1)</sup>	100/150 <sup>1)</sup>	125
$c_{cr,fi}$	Critical edge distance:	R30 to R120 [mm]	2 x $h_{ef}$					
$c_{min,fi}$	Minimum edge distance:	R30 to R120 [mm]	$c_{min} = 2 \times h_{ef}$ ; if fire attack comes from more than one side, the edge distance of the anchor has to be $\geq 300$ mm and $\geq 2 \times h_{ef}$					
<b>Concrete pry out failure</b>								
$k_s$	Pryout factor:	R30 to R120 [-]	1	2	2	2	2	2

<sup>1)</sup> Respective values for anchors MTP, MTP-AT / MTP-G, MTP-X

<sup>2)</sup> As a rule, splitting failure can be neglected since cracked concrete and reinforcement is assumed.

In absence of other national regulations the partial safety factor for resistance under fire exposure  $\gamma_{m,fi} = 1,0$  is recommended

MTP anchors

Performances

Essential characteristics under fire exposure

Annex C11



**Table C14: Essential characteristics under fire exposure MTP-A4 anchor**

Essential characteristics under fire exposure			Performances				
			M8	M10	M12	M16	M20
<b>Steel failure</b>							
N <sub>Rk,s,fi</sub>	Characteristic tension resistance:	R30 [kN]	4,20	7,11	11,00	20,49	31,97
		R60 [kN]	2,96	5,84	10,16	18,93	29,53
		R90 [kN]	1,73	3,47	6,10	11,37	17,74
		R120 [kN]	1,11	2,28	4,08	7,59	11,85
V <sub>Rk,s,fi</sub>	Characteristic shear resistance:	R30 [kN]	4,20	7,11	11,00	20,49	31,97
		R60 [kN]	2,96	5,84	10,16	18,93	29,53
		R90 [kN]	1,73	3,47	6,10	11,37	17,74
		R120 [kN]	1,11	2,28	4,08	7,59	11,85
M <sup>0</sup> <sub>Rk,s,fi</sub>	Characteristic bending resistance:	R30 [Nm]	4,30	9,16	17,09	43,45	84,70
		R60 [Nm]	3,03	7,53	15,79	40,14	78,24
		R90 [Nm]	1,77	4,47	9,49	24,12	47,01
		R120 [Nm]	1,14	2,95	6,34	16,10	31,39
<b>Pull out failure</b>							
N <sub>Rk,p,fi</sub>	Characteristic resistance:	R30 [kN]	2,1	3,5	4,8	6,74	8,60
		R60 [kN]	1,7	2,8	3,8	5,39	6,88
		R90 [kN]					
		R120 [kN]					
<b>Concrete cone failure <sup>1)</sup></b>							
N <sub>Rk,c,fi</sub>	Characteristic resistance:	R30 [kN]	2,7	4,8	7,1	11,5	17,2
		R60 [kN]					
		R90 [kN]					
		R120 [kN]	2,2	43,8	5,6	9,2	13,8
S <sub>cr,N,fi</sub>	Critical spacing:	R30 to R120 [mm]	4 x h <sub>ef</sub>				
S <sub>min,fi</sub>	Minimum spacing:	R30 to R120 [mm]	42	47	57	75	100
C <sub>cr,N,fi</sub>	Critical edge distance:	R30 to R120 [mm]	2 x h <sub>ef</sub>				
C <sub>min,fi</sub>	Minimum edge distance:	R30 to R120 [mm]	c <sub>min</sub> = 2 x h <sub>ef</sub> ; if fire attack comes from more than one side, the edge distance of the anchor has to be ≥ 300 mm and ≥ 2 x h <sub>ef</sub>				
<b>Concrete pry out failure</b>							
k <sub>s</sub>	Pryout factor:	R30 to R120 [-]	1	2	2	2	2

<sup>1)</sup> As a rule, splitting failure can be neglected since cracked concrete and reinforcement is assumed.

In absence of other national regulations the partial safety factor for resistance under fire exposure  $\gamma_{m,fi} = 1,0$  is recommended

MTP anchors

Performances

Essential characteristics under fire exposure

**Annex C12**

